

TIPTOEING THROUGH THE TULIPS TO PROTECT POWER PLANTS

Engineers at ABB are using multiphysics simulation to continuously improve the current-carrying capacity of their generator circuit breakers, protecting power plants around the world from current surges and ensuring uninterrupted generation of electricity.

By **ZACK CONRAD**

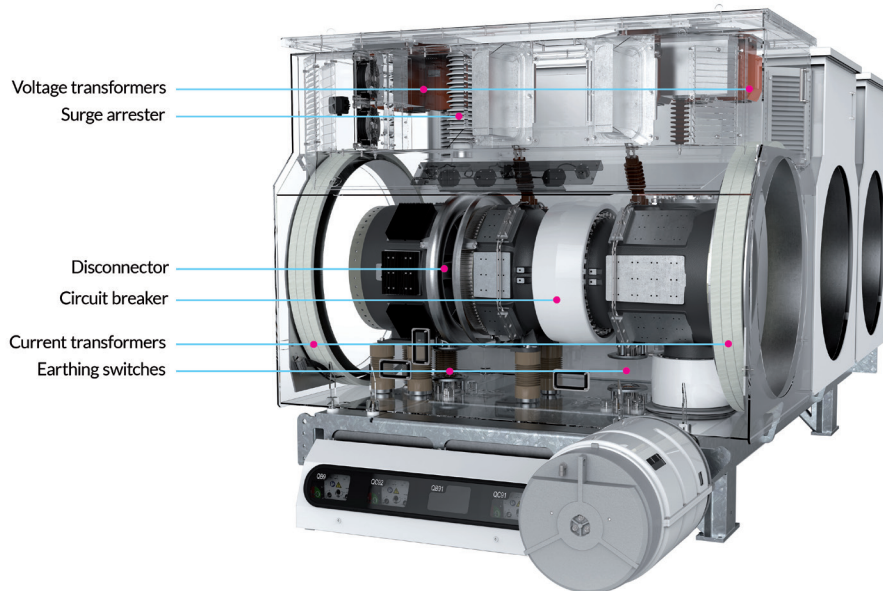

Figure 1. An inside view of an ABB generator circuit breaker (HEC10-210). Image credit: ABB.

IN SOME WAYS power plants are the backbones of modern society. With systems as integral to technological order as these, protection against downtime is pivotal. Whether it's a nuclear, coal-fired, or hydropower plant, they all have one insurance and protection policy in common: generator circuit breakers (GCBs). Playing a key role in power plant protection, GCBs protect plants from high surges of current (Figure 1). By interrupting potentially harmful short-circuit fault currents caused by faulty wiring or grid issues within tens of milliseconds, GCBs prevent important plant assets from severe damages. In a world where the smallest downtime can potentially cost millions of dollars, it is no surprise that these devices are so critical. ABB Group, a multinational leader in electrification products, robotics and motion, industrial automation, and power grids, develops GCBs to safeguard power plants around the world.

The challenge of dealing with short circuit current surges is that they can arise from either the grid or the generator

at any given time. Because of this, GCBs must not only be extremely reliable, but they must have exceptional availability and be able to operate flawlessly, even after a long period of dormancy. Under normal operation, the GCB is a regular, low-resistance part of the circuit that connects the generator to the transformer and the grid. The GCB transfers the generated electric energy to the high-voltage transmission system in a dependable

way. But when needed, it must be able to interrupt currents many times larger than normal operating conditions and extinguish them without damaging other components.

» GROUNDING THE SYSTEM WITH TULIP SWITCHES

EMPLOYED IN THOUSANDS OF POWER plants around the world, the GCBs developed by ABB provide a safe and reliable connection, with a lifetime of at least 30 years. But Francesco Agostini, Alberto Zanetti, and Jean-Claude Mauroux, engineers at ABB, are continuously improving their designs to keep up with modern demands. When an upgraded version is developed, there are extensive testing standards that must be met in order to warrant commercial use. Some of these standards apply to the earthing switches (Figure 2), a critical safety component within the circuit breaker system. "The task of an earthing switch is to ground energized parts of a system, electrically connecting them to the earth," Mauroux explains.

"They are also used to protect personnel while working on operational equipment and must therefore be very reliable and safe, even under adverse climactic conditions."

There is a delicate balance that must be met for an earthing switch design. A well-known design that ABB uses for their earthing switches is a tulip configuration. This design employs silver-plated fixed and sliding contact fingers that provide a disconnecting contact for current to flow through and springs to apply static forces to each

TYPICAL SINGLE LINE DIAGRAM

1. Generator circuit breaker
2. Series disconnecter
3. Capacitors
4. Starting disconnecter for SFC
5. Manual short-circuit connection
6. Earthing switches
7. Current transformers
8. Potential transformers
9. Surge arresters
10. Motorized short-circuit connection

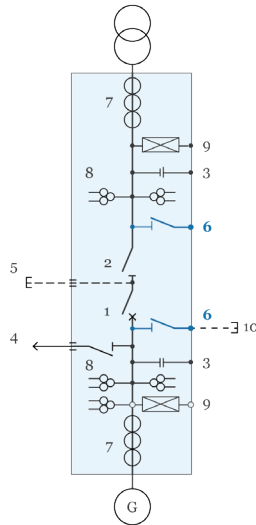

Figure 2. Typical single line diagram of a circuit breaker system showing the placement of the earthing switches.

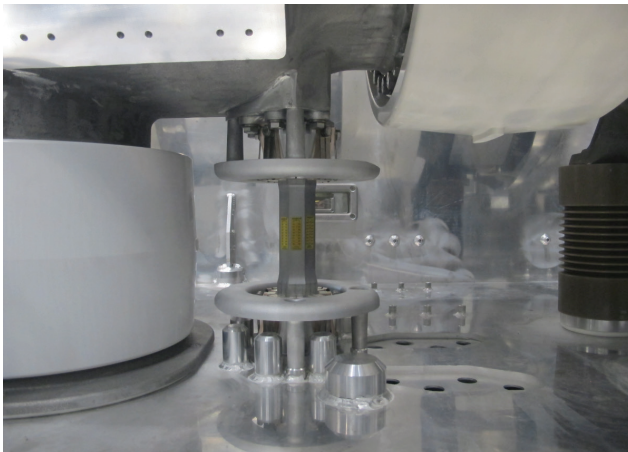

Figure 3. Earthing switch in closed position in a GCB. The moving pin connects the upper and lower tulip contacts. Image credit: ABB.

finger. On one hand, it must be able to withstand the full short circuit fault current according to the International Electrotechnical Commission (IEC) standards when the contact is closed (Figure 3). On the other hand, the tremendously high currents cause large electromagnetic forces to arise, and the side effects of these must be

managed accordingly.

The ultimate focus of the contact system of an earthing switch is the current-carrying capacity, but to understand the complex effects of the contact force on it, Agostini, Zanetti, and Mauroux needed the assistance of multiphysics simulation to quantify the total forces acting on the contact. Using the

“ We passed the type tests with room to spare, demonstrating the harmony in which simulation and experimentation can exist.”

—FRANCESCO AGOSTINI, HEAD OF TECHNOLOGY DEVELOPMENT GCBS AND MATERIALS, ABB

COMSOL Multiphysics® software, they proceeded to construct an earthing switch tulip contact model to simulate the coupled electromechanical behavior.

» FINGERS, FIELDS, AND FORCES

THE EFFECTS OF THE ELECTROMAGNETIC forces that act on the fingers of the tulip contact are twofold. The Holms force, a force that stems from electrical contact points, causes a repulsion. The Lorentz force, a force on a current-carrying object in a magnetic field, causes an attraction. The issue lies with ensuring the attractive force is far greater. A repulsion of the fingers can lead to a lower contact force and possibly separation, significantly increasing the electrical resistance of the contact. A higher resistance leads to higher resistive losses, and those higher losses come with sharp increases in temperature, which can damage the GCB and the earthing switch by welding its contacts. Therefore, the contact force must be adequately large. The tulip contact is an intrinsic solution, which follows the Lorentz law. The welding current capacity further justifies the need for large contact forces. The tulip design plays a vital part in obtaining sufficiently high welding currents and negating the repulsive electromagnetic forces. The ability to withstand high welding currents ensures the extinguishing of the high load without melting the tulip contacts (Figure 4), which guarantees a safe and reliable operation of the entire GCB under extreme conditions. “The object of this tulip design is to provide not just a disconnecting contact, but flat springs to apply static radial pressure to the contact fingers,” Mauroux says. “The increased Lorentz force will assist the contact forces and contribute to reaching much higher welding currents.”

Evaluating the total force on the contacts requires multiple types of physics to be coupled: The electric current flowing through each finger creates a magnetic field, and each magnetic field in turn creates forces on every other finger because of their respective currents. The team used multiphysics simulation to calculate the force in a variety of ways, lending robustness and credibility to their calculations that have been validated against experiments. They exploited the symmetry of the system to simplify their model and reduce the computational effort. They modeled a single finger (Figures 5 and 6) to capture the behavior of the entire tulip at 1/8th of the computational cost. Using Maxwell’s stress tensor, Lorentz force calculations confirmed that the attractive force dominates the repulsive Holms force and that

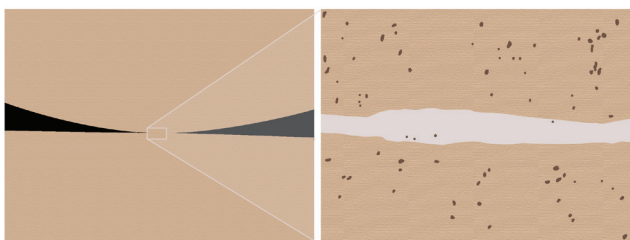

Figure 4. Welding zone. Left: Section of the welded tip (top) onto the pin (bottom). Right: Detail of the welding zone showing the formation and solidification of molten metals forming an alloy. Image credit: ABB.

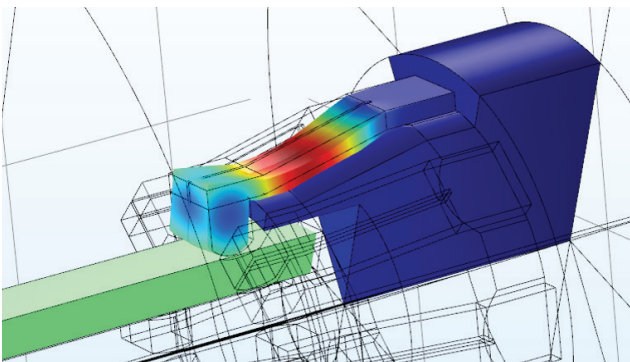
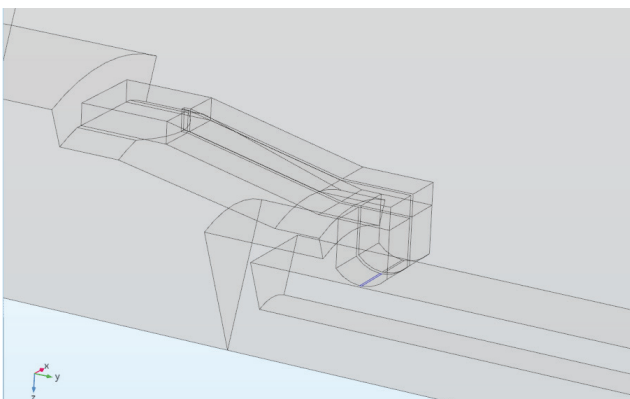

Figure 5. Top: Contact geometry. Bottom: Deformation of a single finger of a tulip design. Image credit: ABB.

the tulip design prevents separation. The simulated total force value can then be used to calculate a theoretical welding current value, which confirmed the ability to carry higher welding currents.

» SIMULATION AND EXPERIMENTATION IN HARMONY

ONCE THE SIMULATION WAS COMPLETE, the actual design needed to undergo numerous testing procedures. These tests

include dielectric type tests to guard against electrical breakdowns, mechanical endurance tests, and operating temperature tests. Finally, and perhaps most importantly, is the KEMA power test, where the theoretical current values need to be verified experimentally to confirm adherence to IEC current-carrying standards. An empirical investigation is set up to determine a measured value for the

welding current, where the switch is exposed to power-plant-like conditions. To become certified, the switch must be capable of delivering peak current in excess of 500 kA. “We passed the type tests with room to spare, demonstrating the harmony in which simulation and experimentation can exist. COMSOL is a very nice tool to combine with empirical testing,” says Agostini. “The intuitive interface helped us involve many different physics in a structured and controlled way.”

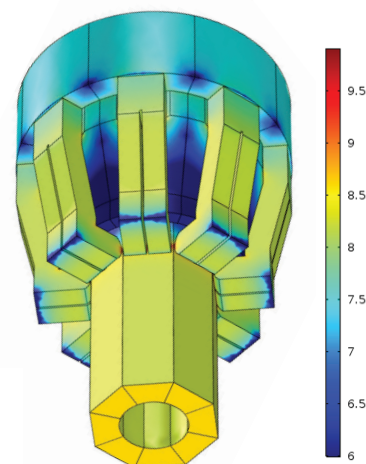
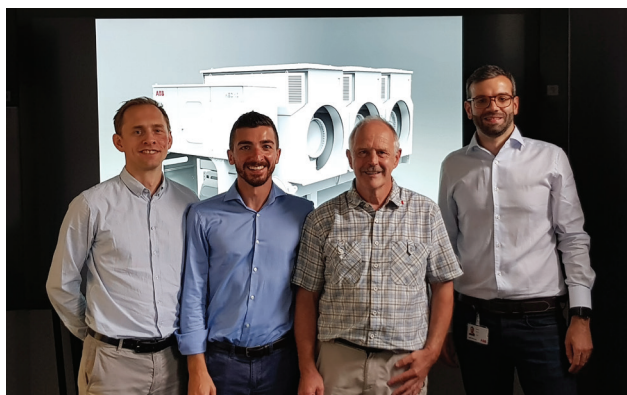

Figure 6. Log of the current density distribution of a tulip configuration. Image credit: ABB.

» A FULL ELECTRO-THERMAL-MECHANICAL MODEL

THE TEAM'S ULTIMATE GOAL is to create a full electro-thermal-mechanical model to simulate more complex designs and gain a comprehensive understanding of all of the physics going on in their earthing switches. Furthermore, careful analysis of the physical and chemical processes behind the contact welding mechanism is something they plan to work on in the future. “Continued advancement in the material selection and modification is fundamental to improving the reliability and performance of our products,” Mauroux says. “Simulation tools will be developed and extensively adopted and we believe COMSOL is up to the challenges of the future when even more complex situations need to be modeled.” ©



From left to right: Markus Bujotzek, technology manager GCBs; Francesco Agostini, head of technology development GCBs and materials; Jean Claude Mauroux, principal engineer, GCBs technology development; Alberto Zanetti, research engineer, materials.